

Transformer Fault Simulation and Analysis Based on Fractional Calculus

Xue Li
Electrical Engineering School
Shandong University
Jinan, China
1157686326@qq.com

Hui Zhong*
Electrical Engineering School
Shandong University
Jinan, China
zhonghui@sdu.edu.cn

Hao Liu
State Grid Binzhou Power Supply
Company
Binzhou, China
relayp@163.com

Yuanyuan Sun
Electrical Engineering School
Shandong University
Jinan, China
sunyy@sdu.edu.cn

Ankang Chen
Electrical Engineering School
Shandong University
Jinan, China
chenshengrui1@126.com

Dongwei Qiao
State Grid Taian Power Supply
Company
Taian, China
283453643@qq.com

Abstract—As grounding fault process of the transformer is complex, the traditional integer-order model cannot accurately reflect the transient characteristics of the transformer, which would make it difficult to develop the transformer real-time monitoring and detecting systems. This paper proposes and establishes a fractional order transient model for power transformer based on the improved Oustaloup filtering algorithm. The fractional order operator is introduced into transformer fault mathematic and simulation models under single-phase ground fault condition. Compared with integer order model, the fractional order model can accurately calculate the currents distribution of transformer windings and the dynamic characteristics under single-phase ground fault condition. The simulation results of the fractional order model of transformer verify the correction of the mathematic model.

Keywords—transformer, fractional order, ground fault

I. INTRODUCTION

The ground fault of the transformer would directly threaten the power supply reliability of the power system and the safe and stable operation of the power grid, which would result in serious economic losses and fatal damage to the power system. Accurate modeling of the power transformer is very important for transformer real-time monitoring and prognosis systems. The traditional integer order transformer model would not accurately analyze the transient process while a ground fault occurs.

The first application of fractional order calculus in physics would be found in [1], in which Richard L. Magin presented an excellent long review on fractional calculus in bioengineering. Jonscher pointed out that the capacitive reactance form of integer order capacitance violates the fractional order characteristics exhibited by dielectric materials [2], whereas integer order capacitance does not exist in fact. Westerlund also pointed out that the actual inductance is also fractional in nature [3]. Now, fractional order calculus has been widespread used in different engineering applications. The research results show that the mathematical model of the actual system based on fractional calculus is more accurate than the mathematical model based on integer-order calculus. It also reflects the nature of these practical systems, and would achieve the unity of the mathematical model and the actual system.

Some research started to apply fractional theory to power device recently. Reference [4] proposed a fractional order electric field optimization model for the design of power capacitors, which would well solve the problem of uneven electric field distribution in the insulation by integer-order model. Considering the capacitance fractional characteristics of insulation system and winding impedance, [5-7] established the models of fractional-order parameters for transformer windings with different voltage levels and the simulations results verified the model. In order to study the triggering conditions of the ferromagnetic resonance of the transformer and its performance, the integer-order ferromagnetic resonance circuit model of the transformer was further extended to the fractional calculus condition to obtain the system model [8-9]. But the above research did not consider that the inductance of the transformer is also fractional in nature.

Considering the fractional feature of the inductance, this paper proposed a fractional order transient model for power transformer under grounding fault condition based on an improved Oustaloup filtering algorithm. The simulation model was set up to verify the mathematic model by comparing with the integer order model.

II. FRACTIONAL ORDER TRANSFORMER MODEL

There are generally two ways to simulate the fractional order capacitor and inductor [10]. The first way is directly using the definition to calculate the approximation of a equation from their voltage-current relationship [11]. The other is using various filtering algorithms to simulate the signals, whose function model cannot be formed [12]. These methods include Oustaloup's, Carlson's, and Charef's.

A. Fractional Order Operator and Rational Realization

The unified calculus operator includes fractional order and integer order, which can be expressed by operator expression.

$${}_a D_t^\lambda f(t) = \begin{cases} \frac{d^q}{dt^q} f(t), & R(q) > 0 \\ f(t), & R(q) = 0 \\ \int_a^t f(\tau) (d\tau)^{-q}, & R(q) < 0 \end{cases} \quad (1)$$

This work was supported by The National Key Research and Development Program of China under grant # 2018YFB0904800.

Where, a and t are the upper and lower limits of the operation, q is the order of calculus operator. While $q > 0$, ${}_a D_t^q$ is fractional differential and ${}_a D_t^{-q}$ is fractional integral respectively.

There is few researches about complex number and irrational number order calculus, and none of them is applied in industry so far. The common definitions of fractional calculus include Riemann-Liouville (RL), Grunwald-Letnikov (GL) and Caputo. Among the three definitions of fractional order, the initial value condition of fractional order calculus defined by Caputo is integer order, which can be better fused with integer order. Therefore, this paper picks the fractional order calculus defined by Caputo as basic theory.

$$D^\alpha f(t) = D^{-(n-\alpha)} [f^{(n)}(t)] = \frac{1}{\Gamma(n-\alpha)} \int_0^t (t-s)^{n-\alpha-1} f^{(n)}(s) ds \quad (2)$$

Where, $n-1 < \alpha \leq n$, D^α is a fractional differential operator, and $\Gamma(\cdot)$ is a gamma function.

B. Fractional Order Transformer Model

The fractional order relationship of the voltage and current for the inductance is:

$$U_L = L D^\alpha I_L = L \frac{d^\alpha I_L}{dt^\alpha} \quad (3)$$

Where, $0 < \alpha < 1$.

Thus, the fractional order transformer model is:

$$[U] = [R][I] + [L]D^\alpha [I] \quad (4)$$

Usually, the circuit of the three-phase double-winding power transformer would be simplified into six branches with mutual inductance, as shown in fig. 1.

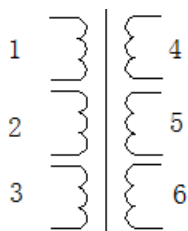

Fig. 1 Transformer multiphase coupling branch model

The transformer mathematic model would be a sixth-order resistance matrix $[R]$ and a sixth-order inductance matrix $[L]$.

$$[R] = \text{Diag} [R_1 \ R_2 \ R_3 \ R_4 \ R_5 \ R_6] \quad (5)$$

$$[L] = \begin{bmatrix} L_1 & M_{12} & M_{13} & M_{14} & M_{15} & M_{16} \\ M_{21} & L_2 & M_{23} & M_{24} & M_{25} & M_{26} \\ M_{31} & M_{32} & L_3 & M_{34} & M_{35} & M_{36} \\ M_{41} & M_{42} & M_{43} & L_4 & M_{45} & M_{46} \\ M_{51} & M_{52} & M_{53} & M_{54} & L_5 & M_{56} \\ M_{61} & M_{62} & M_{63} & M_{64} & M_{65} & L_6 \end{bmatrix} \quad (6)$$

Where, R_i and L_i are respectively the resistance and inductance of winding i itself; M_{ij} is the mutual inductance between windings i and j ($i, j = 1, 2, 3, 4, 5, 6 \quad i \neq j$).

Considering the symmetry of the transformer, any phase winding would be selected as the fault occurring one. As the grounding fault occurs in one phase winding of the transformer, the fault winding can be regarded as two sub-windings, as shown in Fig. 2.

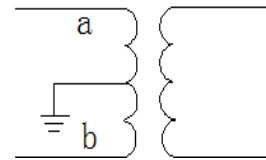

Fig. 2 Model diagram of transformer ground fault

While the ground fault occurs, there would also appear a magnetic field coupled between the two sub-windings, and the resistance matrix of the transformer is changed to the seventh order.

$$[R] = \text{Diag} [R_a \ R_b \ R_2 \ R_3 \ R_4 \ R_5 \ R_6] \quad (7)$$

The inductance matrix $[L]$ is also changed to the seventh order. Inductance L_1 is divided into L_a and L_b , which have mutual inductance with the inductance of other windings.

Thus, the mathematic model of the transformer is:

$$\begin{bmatrix} \frac{d^\alpha I_a}{dt^\alpha} \\ \frac{d^\alpha I_b}{dt^\alpha} \\ \dots \\ \frac{d^\alpha I_6}{dt^\alpha} \end{bmatrix} = [L]^{-1} \begin{bmatrix} U_a \\ U_b \\ \dots \\ U_6 \end{bmatrix} - [L]^{-1} [R] \begin{bmatrix} I_a \\ I_b \\ \dots \\ I_6 \end{bmatrix} \quad (8)$$

C. Ground Fault Equivalent Circuit

Following the above analysis, if the ground fault occurs at the primary coil of a double-winding transformer, the primary coil can be divided into two sub-coils, which is equivalent to a three-winding transformer having a short circuit in the third winding. The composite sequence network diagram of the fault phase can be drawn as shown in Fig. 3.

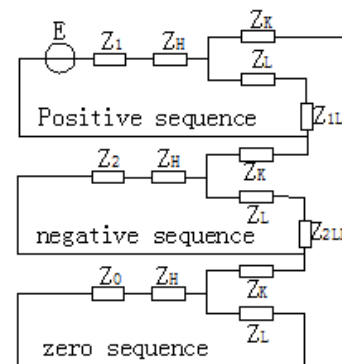

Fig. 3 Composite sequence network diagram of fault components

In Fig.3, Z_H , Z_L and Z_k respectively represent the impedances on the high voltage side, the low voltage side and the short circuit winding side, and Z_{1LD} and Z_{2LD} respectively represent the positive and negative sequence impedances on the low voltage side.

III. TRANSFORMER GROUND FAULT SIMULATION

A. Fractional order Module

Oustaloup filtering algorithm uses integer order transfer function model to approximate fractional calculus operator, which is currently the most commonly used filtering approximation method[13]. Assuming that the frequency segment to be fitted is [wb, wh], the standard form of the filter is as follows:

$$G(s) = K \prod_{k=1}^N \frac{s + w'_k}{s + w_k} \quad (9)$$

Although the algorithm has good approximation effect in the overall fitting frequency band, it is not particularly ideal at both ends of the frequency band. Therefore, the improved Oustaloup filtering algorithm is applied to the relationship between current and voltage of inductances in the transformer.

The expression of the improved Oustaloup filtering algorithm is:

$$S^\alpha \approx \left(\frac{dw_b}{b}\right)^\alpha \left[\frac{ds^2 + bw_h s}{d(1-\alpha)s^2 + bw_h s + d\alpha} \right] \prod_{k=-N}^N \frac{s + w'_k}{s + w_k} \quad (10)$$

Since the numerator and denominator of the filter designed by this algorithm are of the same order, in order to avoid algebraic loop, a low-pass filter is added behind this filter.

The fractional order integration inductance subsystem model can be seen in Fig. 4.

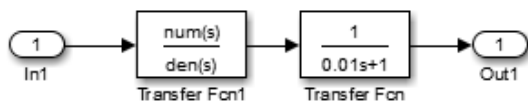

Fig. 4 Fractional subsystem

B. Flux Linkage Calculation Module

To simulating the short-circuit fault in the transformer accurately, this paper uses the winding flux linkage of the transformer as the state variable to build the simulation model of the three-phase transformer. Converting the transformer terminal voltage equation into a flux linkage related equation, there are:

$$\begin{cases} u_1 = i_1 r_1 + \frac{1}{\omega_b} \frac{d^3 \psi_1}{dt} \\ u_2' = i_2' r_2' + \frac{1}{\omega_b} \frac{d^3 \psi_2'}{dt} \\ u_3' = i_3' r_3' + \frac{1}{\omega_b} \frac{d^3 \psi_3'}{dt} \end{cases} \quad (11)$$

$$\psi_m^{sat} = X_m \left(\frac{\psi_1}{x_{1\sigma}} + \frac{\psi_2'}{x_{2\sigma}'} + \frac{\psi_3'}{x_{3\sigma}'} \right) \quad (12)$$

Where ψ_i is the winding flux linkage, ψ_m^{sat} is the saturation value of flux linkage, ω_b is the reference angular frequency when calculating reactance, and $x_{i\sigma}$ is leakage reactance of winding.

The module calculates the value of the state variable flux linkage according to the terminal voltage and the main flux linkage of the three windings, and replaces the integrator with a fractional order module.

It can be obtained from equation (11) and equation (12):

$$\begin{cases} \psi_1 = {}_\alpha D^{-q} \left[\omega_b u_1 - \omega_b r_1' \left(\frac{\psi_1 - \psi_m^{sat}}{x_{1\sigma}} \right) \right] \\ \psi_2' = {}_\alpha D^{-q} \left[\omega_b u_2' - \omega_b r_2' \left(\frac{\psi_2' - \psi_m^{sat}}{x_{2\sigma}'} \right) \right] \\ \psi_3' = {}_\alpha D^{-q} \left[\omega_b u_3' - \omega_b r_3' \left(\frac{\psi_3' - \psi_m^{sat}}{x_{3\sigma}'} \right) \right] \end{cases} \quad (13)$$

The structural framework is shown in fig. 5

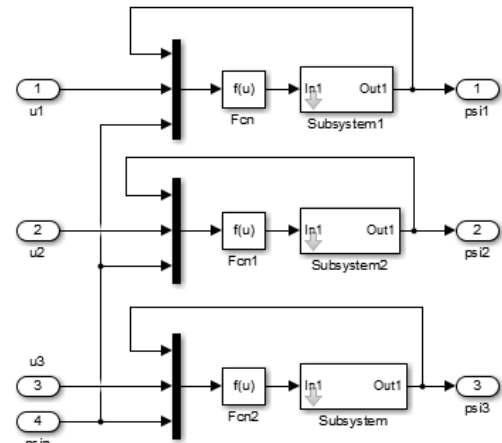

Fig. 5 Flux linkage calculation module

C. Current and Load Module

The current of each winding is calculated according to the flux linkage and the main flux linkage calculated by the flux linkage calculation module. The functional relationship between current and flux linkage is:

$$\begin{cases} i_1 = \frac{\psi_1 - \psi_m^{sat}}{x_{1\sigma}} \\ i_2' = \frac{\psi_2' - \psi_m^{sat}}{x_{2\sigma}'} \\ i_3' = \frac{\psi_3' - \psi_m^{sat}}{x_{3\sigma}'} \end{cases} \quad (14)$$

The input of the load module is the winding current and the output is the winding terminal voltage. By modifying the parameters of the load module, the simulation of the transformer under various operating conditions can be conveniently implemented, such as setting a larger load gain

k , which is equivalent to the open-circuit operation of the winding terminal. Setting the load gain k to zero is equivalent to winding short circuit operation.

The current and load structural frame are shown in Fig.6 and Fig.7.

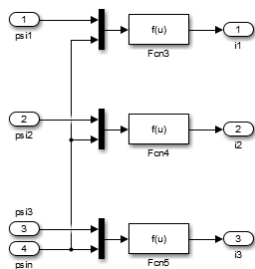

Fig. 6 Current calculation module



Fig. 7 Load module

D. Transformer Simulation Model

The three-phase transformer model built in this paper consists of three independent single-phase transformer modules, as shown in Fig. 8. Each single-phase transformer module comprises a fractional order module, a flux linkage calculation module, a current calculation module and a load module.

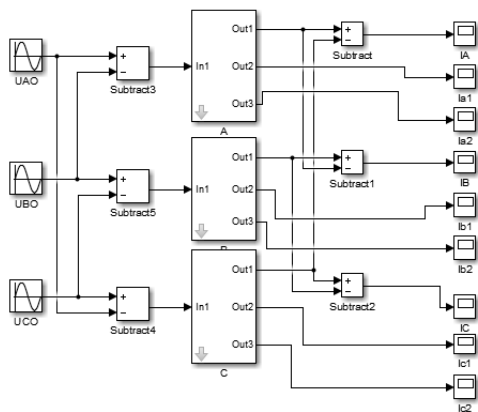

Fig. 8 Three-phase transformer model

The internal structure of each single-phase transformer is shown in fig. 9. Subsystem is the packaged three fractional order module.

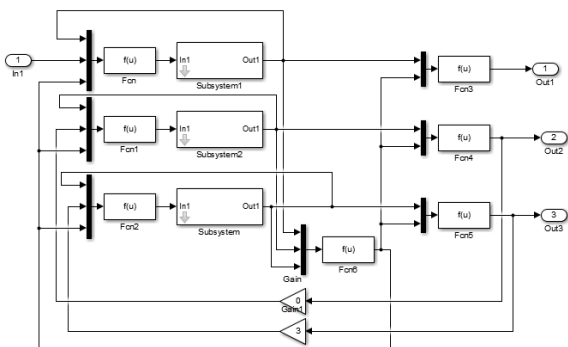

Fig. 9 Internal modules of single-phase transformer

IV. SIMULATION RESULTS AND ANALYSIS

In order to appreciate the interest of fractional model with the modal representation of the fractional integrator, simulation results under turn-to-ground fault state are compared with the integer-order model simulation ones and experimental dates in [14]. The integer order model of the transformer is the model when the fractional order module takes the first order. At this time, the integrator module can be directly used for simulation.

When the transformer has a turn-to-ground fault in phase A, the primary side current waveforms simulated by its fractional order are shown in Fig. 10. The fractional order integral part is accomplished by the modified Oustaloup filtering algorithm. After comparison, the fractional order is chosen as 0.721.

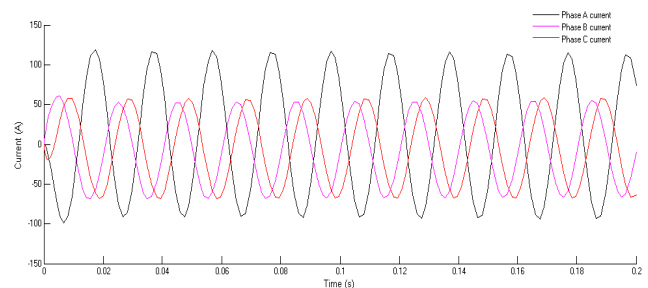

Fig. 10 Fault phase current waveforms

From Fig.10, it can be found there is an increase of phase A current because of the decrease of phase A voltage caused by ground fault. The phenomena of waveform offset and discontinuity angle appear in all three-phase currents. The waveforms bias to one side because of the non-periodic components and the waveforms have obvious discontinuity angle because of the second harmonic component. The results are consistent with those of the fault recorder in [14].

The fault current simulation results by integer order and fractional order are compared in Fig.11.

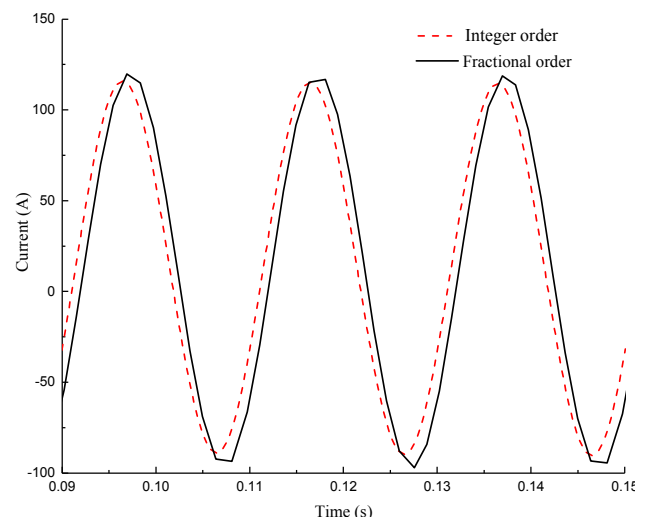

Fig. 11 Fault current waveforms comparison

From Fig.11, it can be seen that waveform bias and discontinuity angle caused by the ground fault do not appear in the integer order simulation results while the fractional order model of the transformer would describe the characters of currents accuracy. The correctness of the fractional order model is verified.

V. CONCLUSION

This paper proposes a fractional calculus-based transient model for power transformer. The currents of transformer windings and the dynamic characteristics of magnetic field under single-phase ground fault condition are calculated and simulated by the fractional model. Through the comparison with the integer order model and experimental results, here are the conclusions:

- 1) The fractional order induction model would accurately reflect the transient characteristics of the transformer and help to improve the accurate and real-time fault detection system of the transformer;
- 2) The winding flux linkage of the transformer is selected as the state variable to build the simulation model by converting the transformer terminal voltage equation into a flux linkage related equation, which describe the dynamic characteristics of magnetic field more easily in the simulation model.

REFERENCES

- [1] R. Hilfer (Editor). Applications of Fractional Calculus in Physics [M], World Scientific Pub Co., Singapore, 2000.
- [2] Bohannan G W. Analog realization of a fractional control element—Revisited[C]. Proceeding of the 41st IEEE International Conference on Decision and Control, Tutorial Workshop 2: Fractional Calculus Applications in Automatic Control and Robotics, 2002, 1
- [3] Westerlund S. Dead Matter Has Memory! [J], Physica Scripta, Vol. 43, No. 2 pp. 174-179, 1991.
- [4] P. Chen, K. Yang and T. Zhang, A dual band impedance transformer realized by fractional-order inductor and capacitor[C]. 2016 IEEE Asia Pacific Conference on Circuits and Systems (APCCAS), Jeju, 2016, pp. 613-616.
- [5] Liang Guishu, Gao Shiqiang. Research on parameter identification of fractional transmission line model for oil-immersed transformer windings[J]. Journal of North China Electric Power University, 2016, 43(5): 1-7
- [6] Liang Guishu, Malone, Shan Dongqing. Two-port fractional-order varactor and its circuit simulation [J]. Journal of North China Electric Power University (Natural Science Edition), 2017,44(06):1-7
- [7] Pan Haiquan. Study on transient digital simulation of three-winding and autotransformer [D]. North China Electric Power University (Beijing), 2009
- [8] Zhang Xun Kang, Liang Hao, Wang Jiao Tong, Han Yu Chao. Analysis of Ferromagnetic Resonance Chaotic System Based on Fractional Calculus Transformer Model [J]. High Voltage Apparatus, Vol53, No12, pp. 202-207, 2017
- [9] Ningning Yang, Yuchao Han, Chaojun Wu, et. al. Dynamic analysis and fractional-order adaptive sliding mode control for a novel fractional-order ferroresonance system [J]. Chin. Phys. B, 2017, 26(8):1-13
- [10] P. Chen, K. Yang and T. Zhang, A dualband impedance transformer realized by fractional-order inductor and capacitor [C]. 2016 IEEE Asia Pacific Conference on Circuits and Systems (APCCAS), Jeju, 2016, pp. 613-616.
- [11] Y. Q. Chen and K. L. Moore, Discretization schemes for fractional-order differentiators and integrators [J]. IEEE Trans. Circuits Syst., Vol.49, No.3, pp.363-367, 2002.
- [12] S. Das, I. Pan, S. Saha, A. Kumar, S. Das and A. Gupta, Revisiting oustaloup's recursive filter for analog realization of fractional order differintegrators [C]. 2011 International Conference on Energy, Automation and Signal, Bhubaneswar, Odisha, 2011, pp. 1-6.
- [13] A. Oustaloup, F. Levron, B. Mathieu and F. M. Nanot, Frequency-band complex noninteger differentiator: characterization and synthesis [J]. IEEE Transactions on Circuits and Systems I: Fundamental Theory and Applications, vol. 47, no. 1, pp. 25-39, Jan 2000.
- [14] Wei Li, Zheng Tao, Peng Jianning, Qi Pengbo, Yang Zheng. Pilot study of three-phase current characteristic on transformer high-voltage side when the clearance is breakdown caused by single-phase grounding fault [J]. Power System Protection and Control, 2010, Vol.38, No.8, pp:140-143